

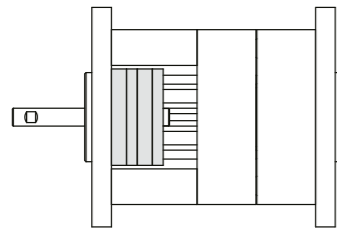

1

ANWENDUNGSBEISPIEL: DEZENTRAL, VORLAUFEND
APPLICATION EXAMPLE: DECENTRALISED, LEADING TYPE

1.1 Werkzeug geschlossen – Spritzstellung.
 Mould closed – injection position.



1.2 Hub 1: Werkzeug offen – Kernstift entformt Innenkontur.
 Stroke 1: Mould base open – core pin demoulds inner contour.

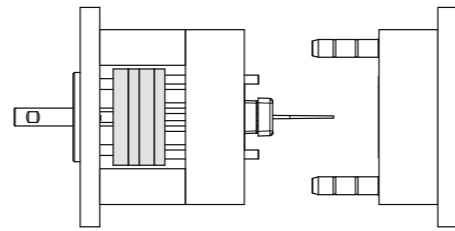

1.3 Hub 2: Werkzeug offen – Kunststoffteil wird vollständig entformt.
 Stroke 2: Mould base open – plastic part is completely demoulded.

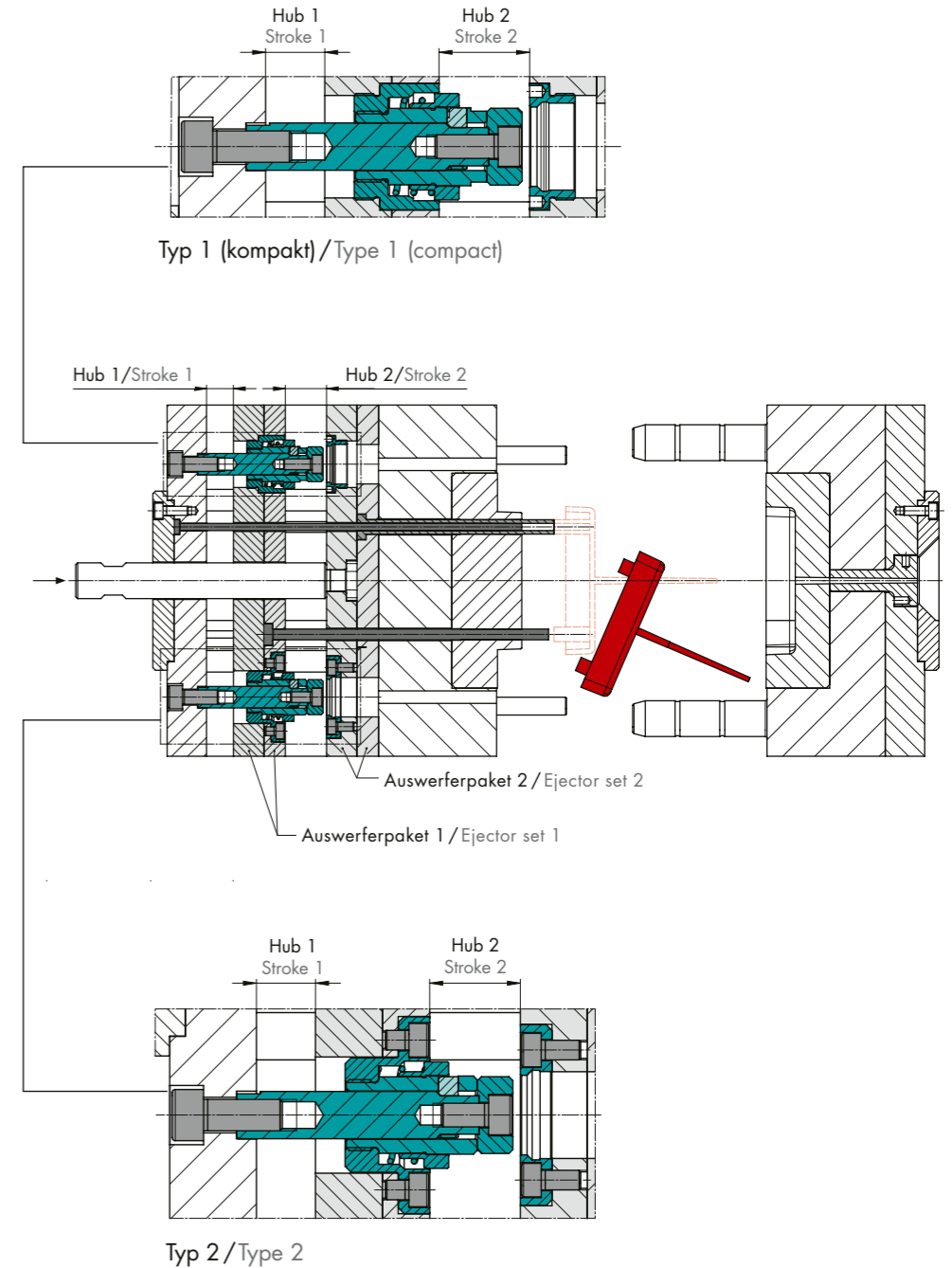
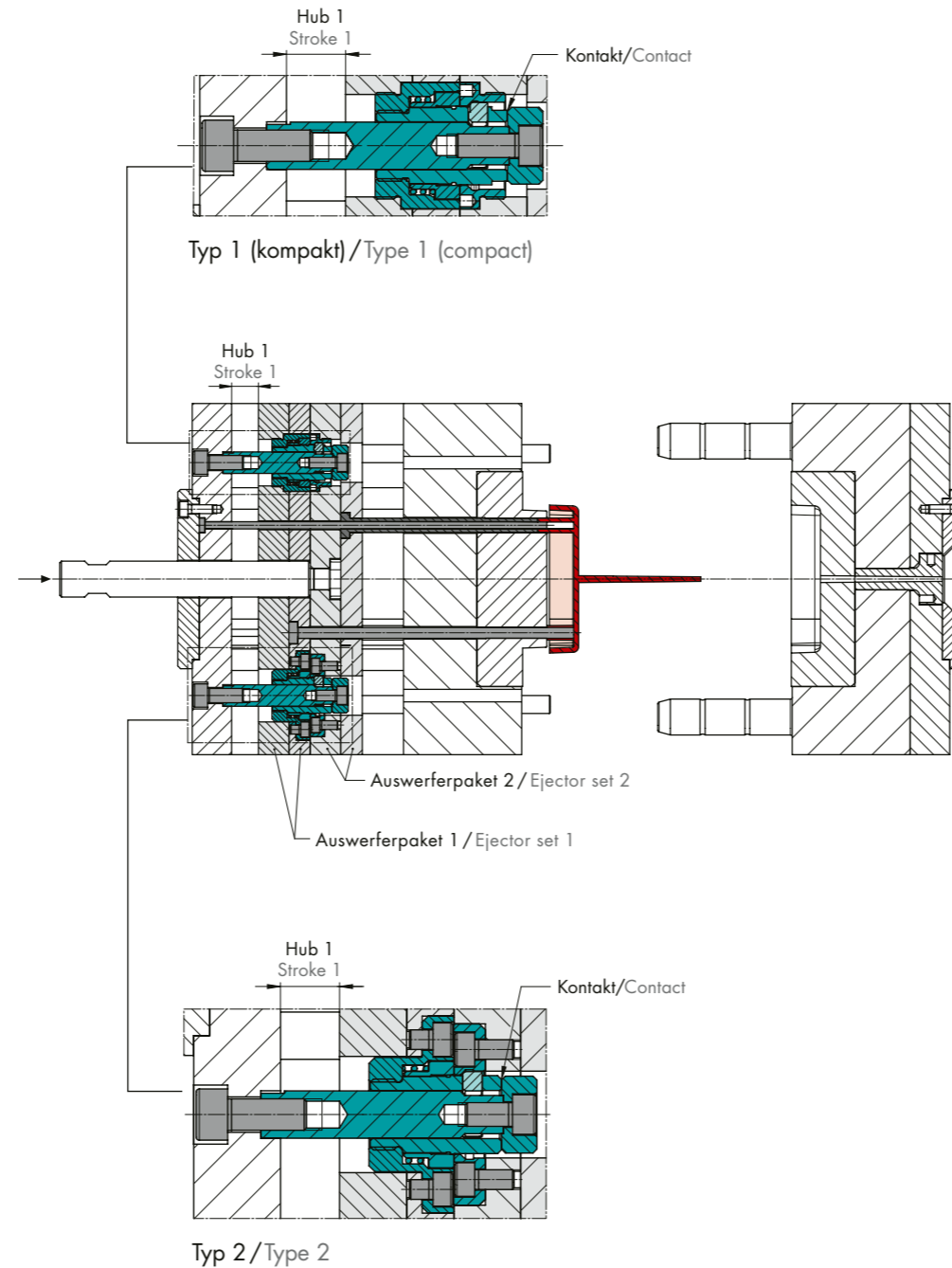
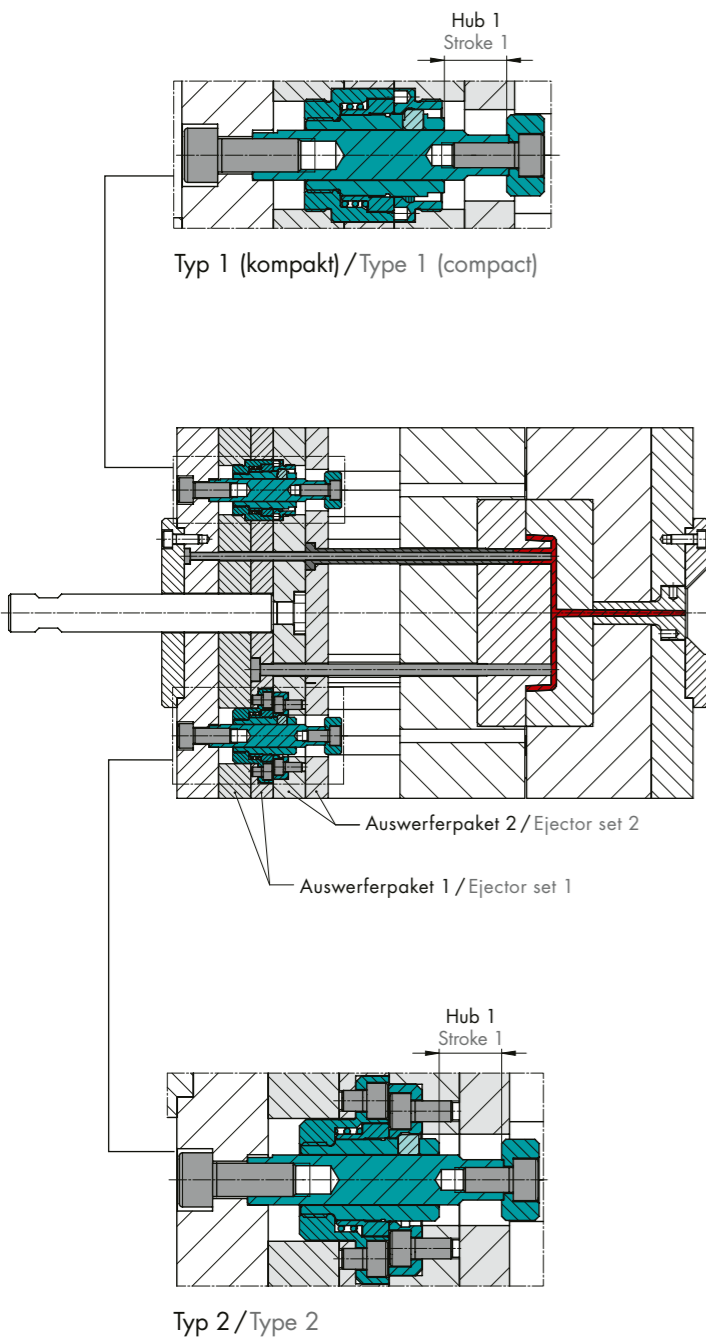
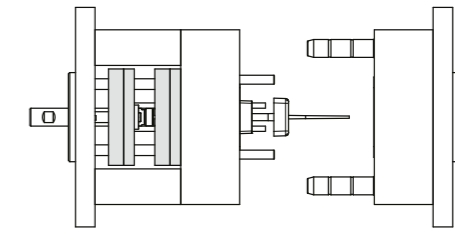



2

ANWENDUNGSBEISPIEL: ZENTRAL, VORLAUFEND APPLICATION EXAMPLE: CENTRALISED, LEADING TYPE

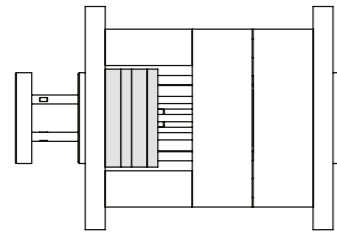

- 2.1 Werkzeug geschlossen – Spritzstellung.
Mould closed – injection position.

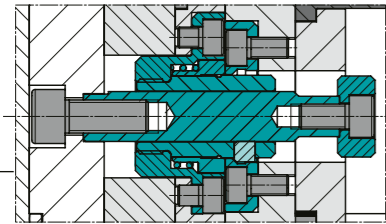

Typ 1/Typ 2
Type 1/Type 2

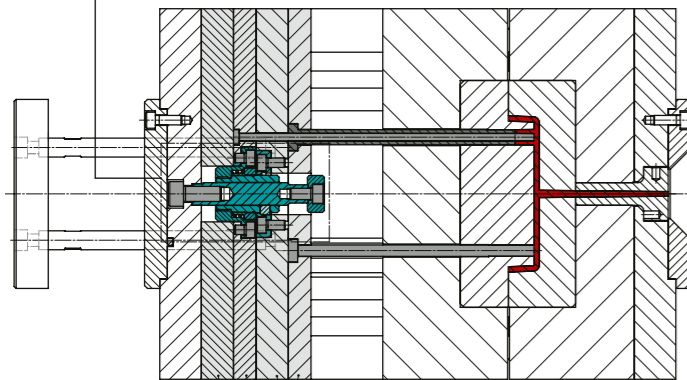

Auswerferpaket 2 / Ejector set 2
Auswerferpaket 1 / Ejector set 1

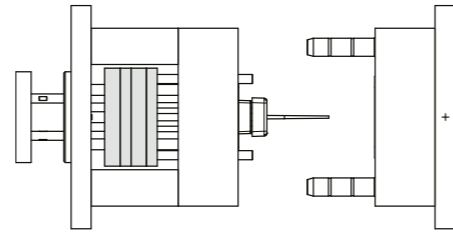

- 2.2 Hub 1: Beide Auswerferpakete werden miteinander um Hub 1 bewegt. Bauteil wird abgehoben, Bauteil sitzt noch auf Auswerfer und Hülse.
Stroke 1: Both ejector sets are moved jointly by stroke 1. Component is lifted off, component still rests on ejector pin and sleeve.

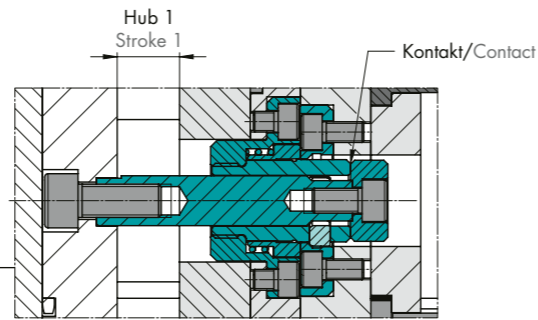

Typ 1/Typ 2
Type 1/Type 2

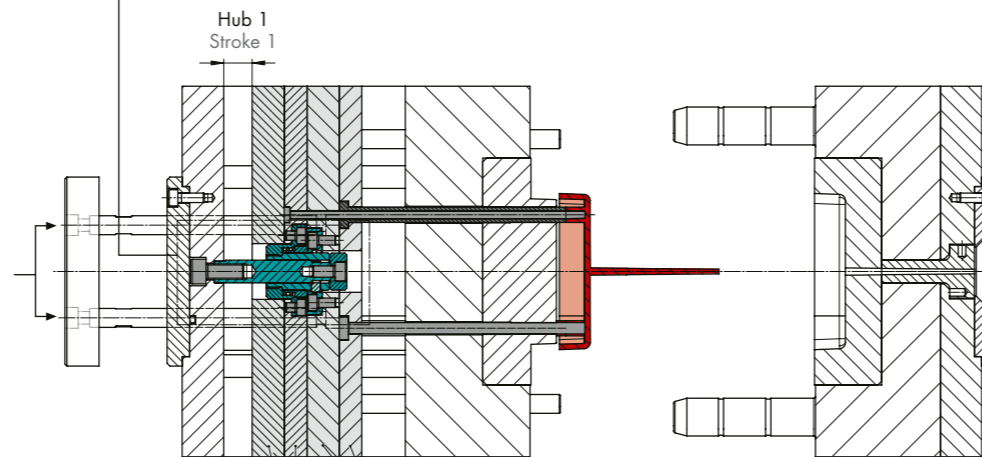

Auswerferpaket 2 / Ejector set 2
Auswerferpaket 1 / Ejector set 1

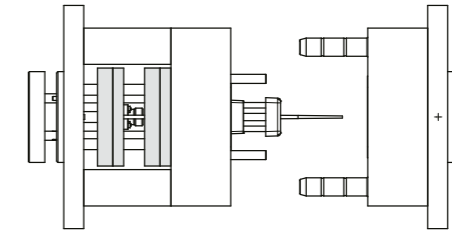

- 2.3 Hub 2: Trennung der beiden Auswerferpakete durch Rundklinkenzug 313000. Auswerferpaket 1 wird auf Position gehalten. Auswerferpaket 2 fährt um Hub 2 weiter vor. Hülse und Auswerfer in Auswerferpaket 2 entformen das Kunststoffteil.
Stroke 2: Separation of the two ejector sets by round latch lock 313000. Ejector package 1 is held in position. Ejector package 2 moves forward by stroke 2. Sleeve and ejector pin in ejector set 2 demould the plastic part.

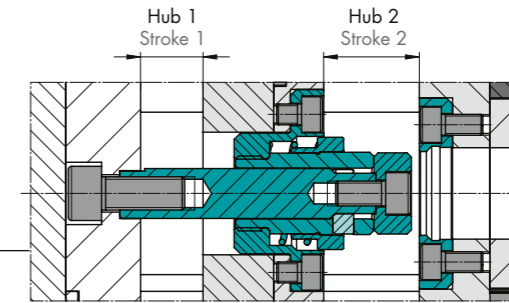

Typ 1/Typ 2
Type 1/Type 2

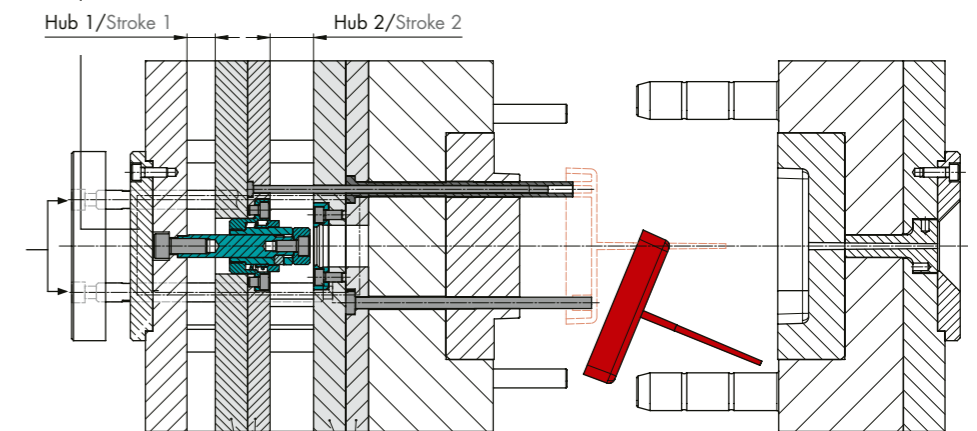

Auswerferpaket 2 / Ejector set 2
Auswerferpaket 1 / Ejector set 1



3 ANWENDUNGSBEISPIEL: DEZENTRAL, NACHLAUFEND APPLICATION EXAMPLE: DECENTRALISED, TRAILING TYPE

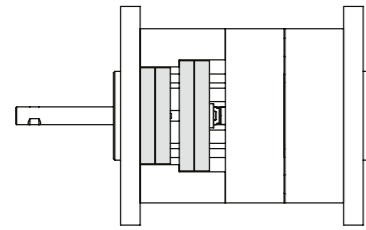

- 3.1 Werkzeug geschlossen – Spritzstellung.
Mould closed – injection position.

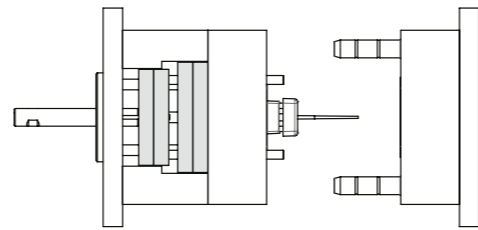

- 3.2 Hub 1: Beide Auswerferpakete fahren mit konstantem Abstand um Hub 1 vor. Schrägschieber entformt, Kunststoffteil hebt ab. Hülse in Auswerferpaket 1 und Auswerfer in Auswerferpaket 2 haben noch Kontakt zum Bauteil.
Stroke 1: Both ejector sets move forward by stroke 1 at a constant distance. Slanted slide demoulds, plastic part lifts off. Sleeve in ejector set 1 and ejector pin in ejector set 2 are still in contact with the component.

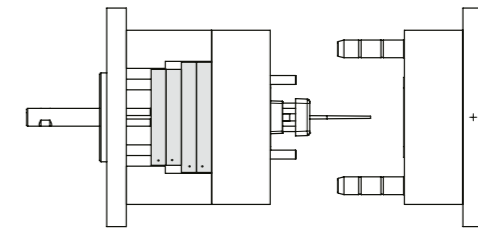

- 3.3 Hub 2: Auswerferpaket 2 bleibt stehen. Auswerferpaket 1 fährt weiter um Hub 2. Hülse in Auswerferpaket 1 entformt Kunststoffteil.
Stroke 2: Ejector set 2 remains at a standstill. Ejector set 1 continues to move by stroke 2. Sleeve in ejector set 1 ejects plastic part.

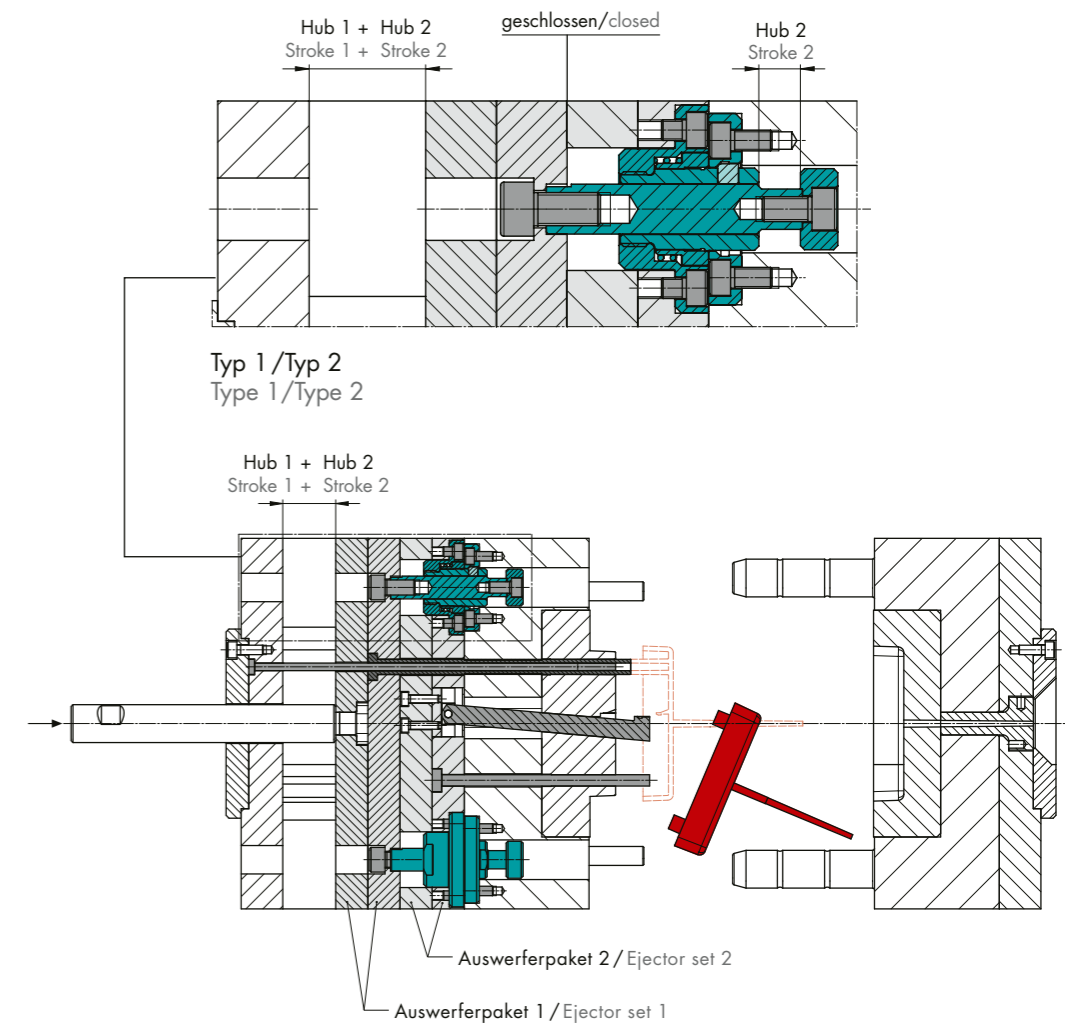
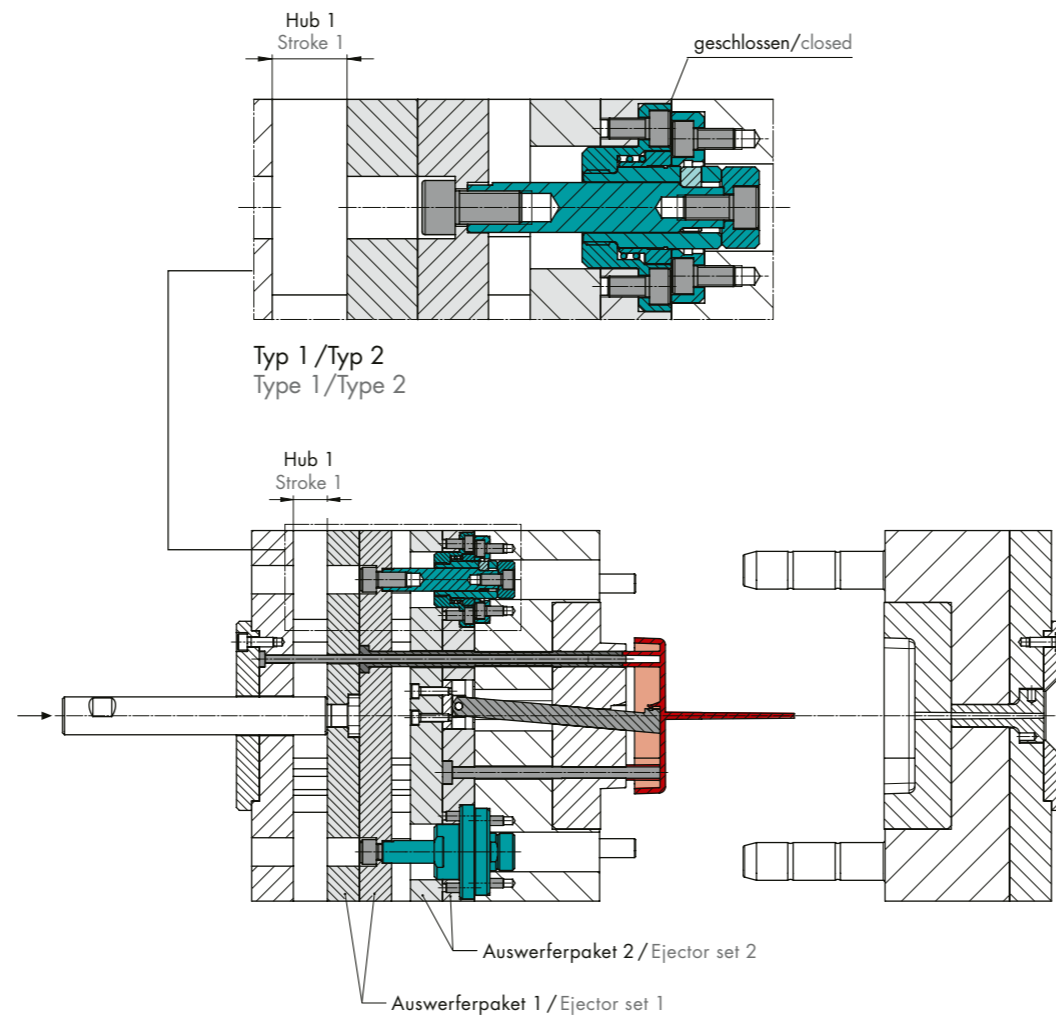
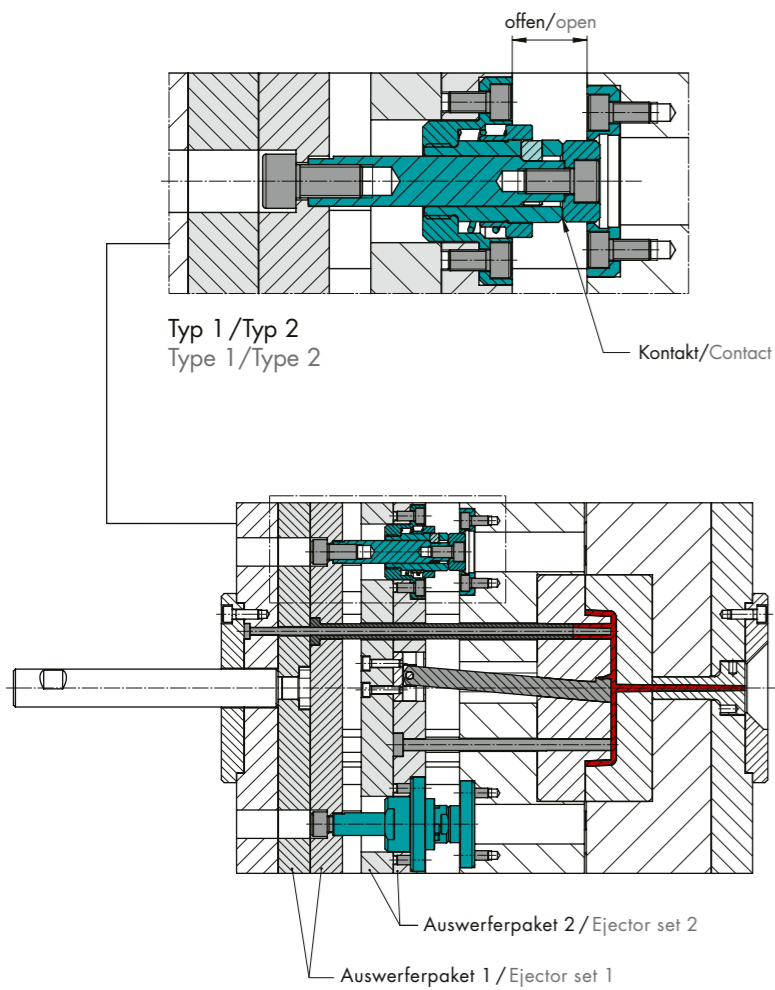



4

ANWENDUNGSBEISPIEL: ABHEBENDE FORMPLATTE DÜSENSEITE
APPLICATION EXAMPLE: LIFTING MOULD PLATE ON NOZZLE SIDE

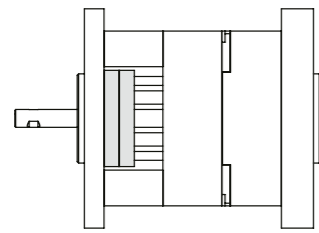

4.1 Werkzeug geschlossen – Spritzstellung
 Mould closed – injection position

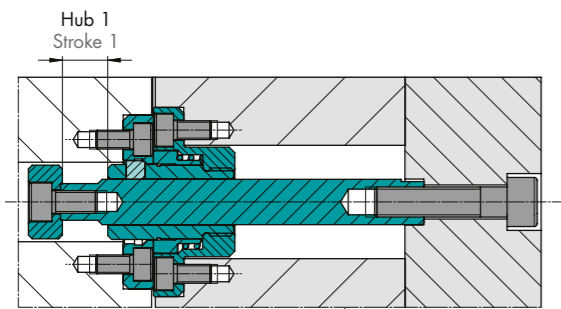

Hub 1
 Stroke 1
 Typ 1/Typ 2
 Type 1/Type 2

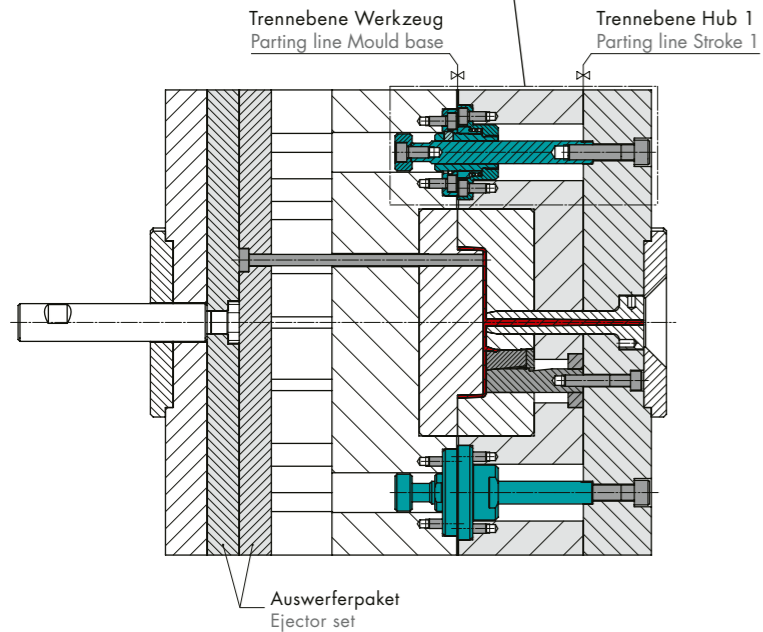

Trennebene Werkzeug
 Parting line Mould base
 Trennebene Hub 1
 Parting line Stroke 1

Auswerferpaket
 Ejector set

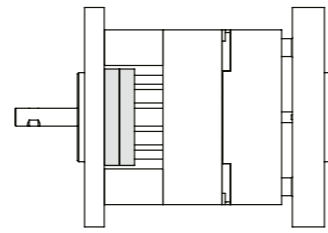

4.2 Werkzeug öffnet. Formplatte Düsenseite hebt um Hub 1 ab.
 Hinterschnitt wird durch bewegliches Element entformt.
 Mould base opens. Mould plate on nozzle side lifts by stroke 1.
 Undercut is ejected by movable element.

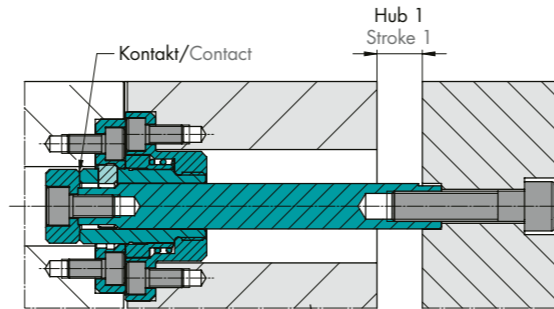

Kontakt/Contact
 Hub 1
 Stroke 1
 Typ 1/Typ 2
 Type 1/Type 2

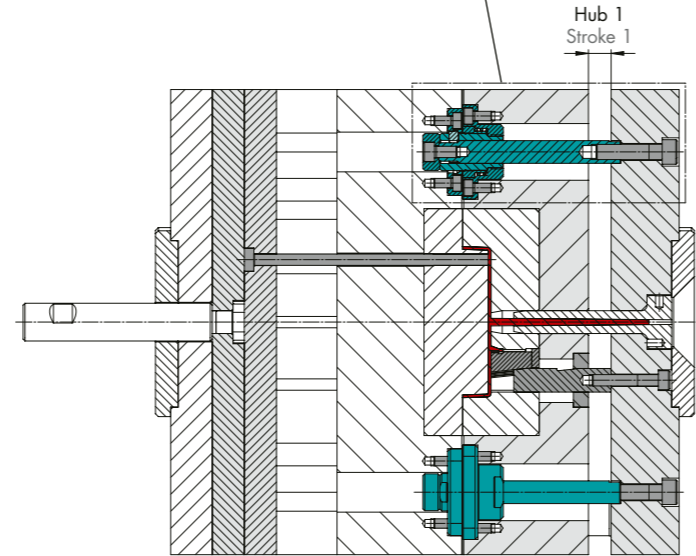

Hub 1
 Stroke 1

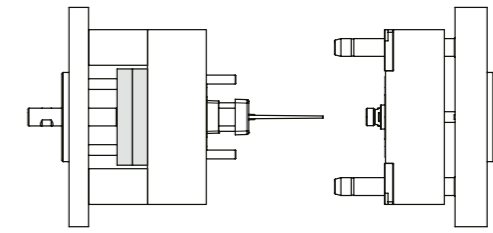

4.3 Hub 2: Werkzeug ist vollständig geöffnet. Auswerferpaket fährt vor und entformt Kunststoffteil.
 Stroke 2: Mould is fully open. Ejector set moves forward and ejects plastic part.

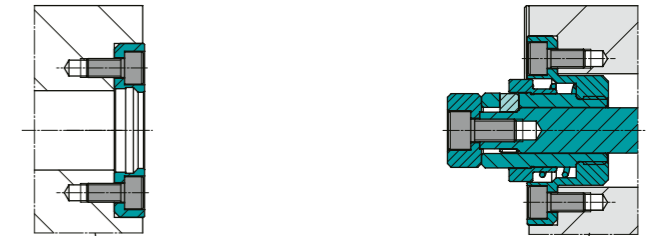

Typ 1/Typ 2
 Type 1/Type 2

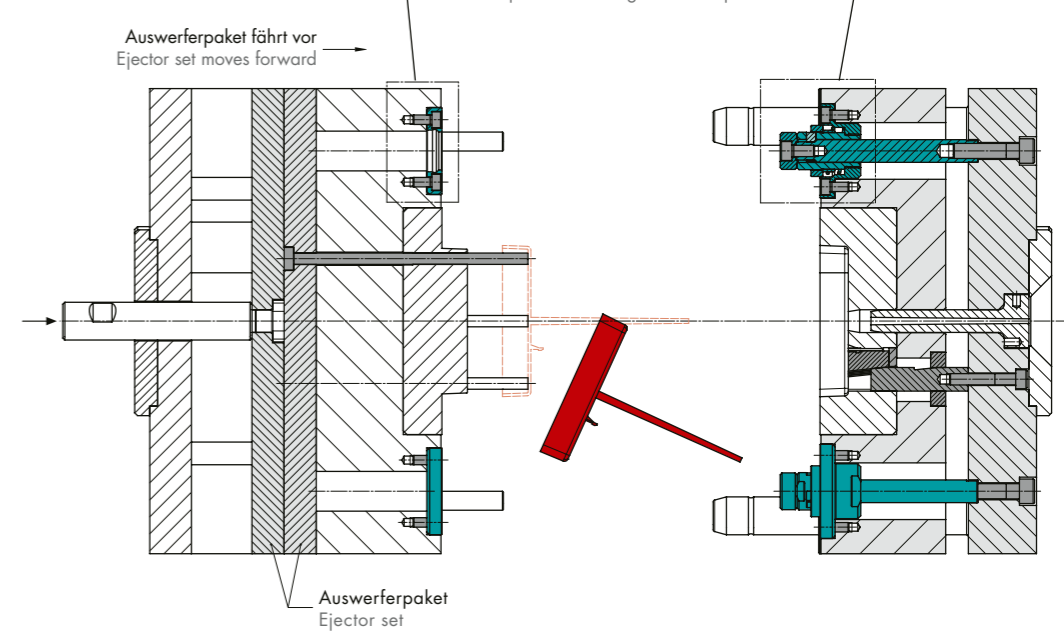

Auswerferpaket fährt vor
 Ejector set moves forward

Spritzgießwerkzeug geöffnet
 Injection moulding machine open

Auswerferpaket
 Ejector set