

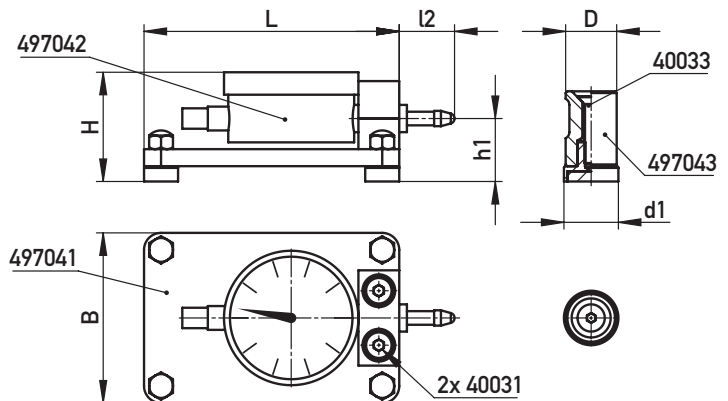

HALTERUNG MIT MESSUHR UND ANSCHLAG, MAGNETISCH

HOLDER WITH DIAL INDICATOR AND BUFFER, MAGNETIC



Messbereich: 5,00 mm
Measuring range: 5,00 mm

Skalenteilung: 0,01 mm
Graduation: 0,01 mm

AUF EINEN BLICK

- ▶ Überwachung der Spritzposition von Spritzgießwerkzeugen
- ▶ Flexible Anwendungsmöglichkeiten durch Neodym-Magneten
- ▶ Hochwertige Messuhr (Artikel 497042)

AT A GLANCE

- ▶ Monitoring of the injection position of mould bases
- ▶ Flexible application options by means of neodymium magnets
- ▶ High-quality dial indicator (Article 497042)

40031	40033	d1	l2	h1	D	B	L	H	€/1
2x M5-14	M4-20	16	15	18,5	15	50	75	33,5	•

☒ 497044

