

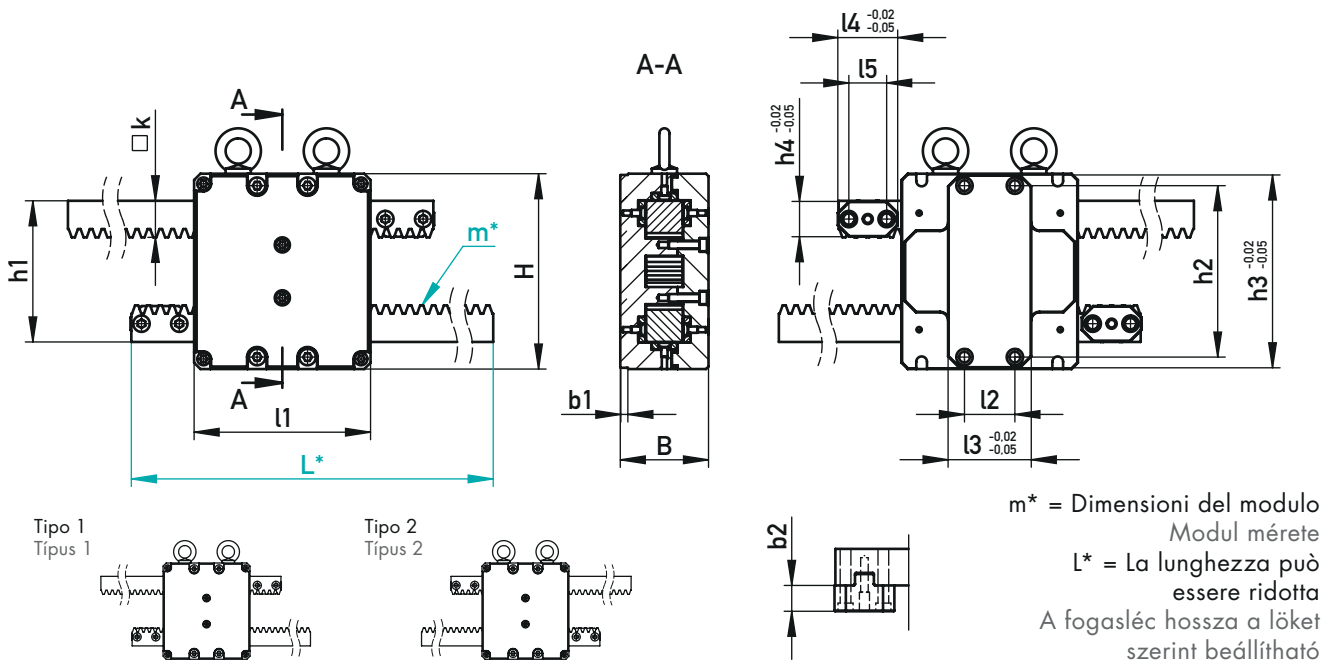

## DISPOSITIVO A CREMAGLIERA FOGASLÉCES HAJTÁS

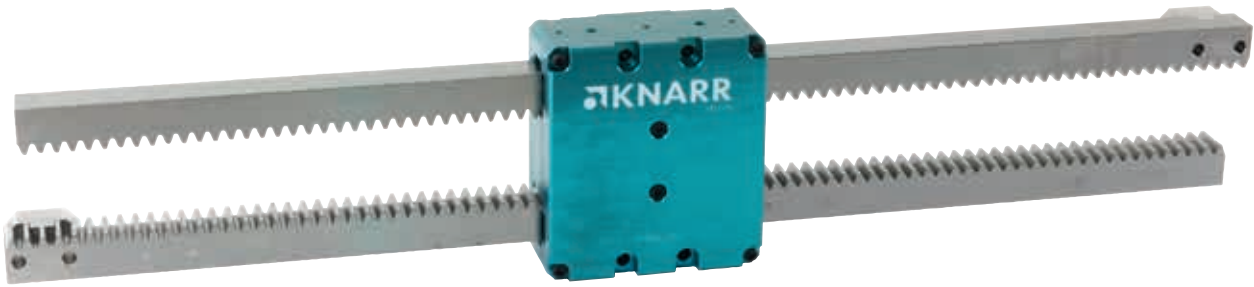

### IN SINTESI

- Design compatto – 30% in meno rispetto a prodotti similari
- Le parti sono pre-assemblate, per un montaggio più facile e veloce
- Soluzione efficiente in termine di costi
- Servizio di taglio a misura

### ÁTTEKINTÉS

- Igen jó helykihasználású szerkezet – több mint 30%-kal kevesebb helyet igényel, mint a hasonló feladatot ellátó hasonló termékek
- A szerelt egységnek egyszerű a kezelése és a beépítése
- Költséghatékony rendszer
- A teljes hossz igény szerint beállítható



I dispositivi devono sempre essere utilizzati sullo stampo a coppie, due o quattro unità.  
Per lunghezza ( $L$ ) > 1000 mm valutare, se necessario, l'aggiunta di ulteriori guide per la cremagliera.  
A terheléstől függően mindig 2 vagy 4 egységet kell szimmetrikusan felszerelni.  
Ha a hosszúság ( $L$ ) meghaladja az 1000 mm-t, ellenőrizze, hogy szükség van-e további fogaslécra.

200 °C

k	b1	l3	h3	b2	h4	l4	h2	l5	l2	h1	l1	B	H	m*	L*	F (kN)	Tipo 1 / Típus 1	Tipo 2 / Típus 2
																	☒	☒
19	3,5	45	88	13,5	18	32	79	18	29	66	78	45,5	89	2	602,5	8	461000/1/2-600	461000/2/2-600
															797		461000/1/2-800	461000/2/2-800
29	6	66	153	20,5	28	47,5	136	30	40	112	140	70	155	3	800	12	461000/1/3-800	461000/2/3-800
															1196		461000/1/3-1200	461000/2/3-1200
39	6	66	188	20,5	38	50	171	30	40	146	185	80	190	4	803	22,5	461000/1/4-800	461000/2/4-800
															1192,5		461000/1/4-1200	461000/2/4-1200
															1494		461000/1/4-1500	461000/2/4-1500
															1796		461000/1/4-1800	461000/2/4-1800



## DISPOSITIVO A CREMAGLIERA FOGASLÉCES HAJTÁS

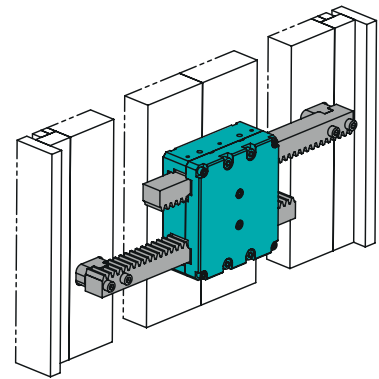
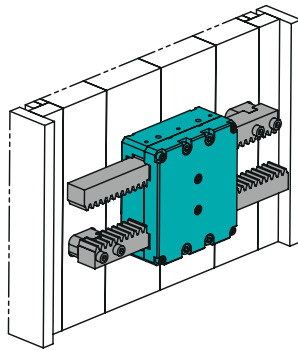
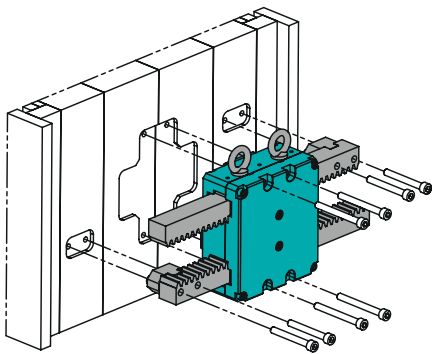

**ASSEMBLAGGIO  
SZERELÉS**

### SEDE DI INSTALLAZIONE • BEÉPÍTÉSI HELY

Esempio Tipo 1  
Példa az 1. típusra

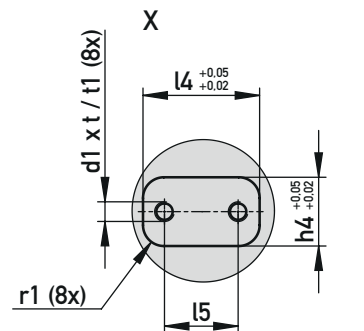
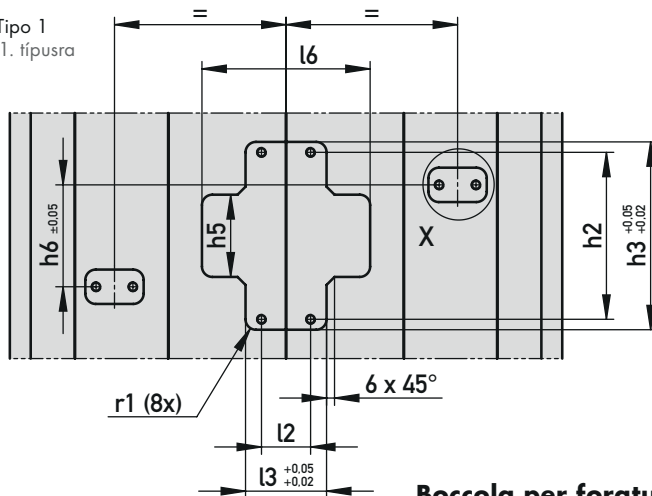

**Boccola per foratura (opzionale)**

Illesztő persely (opcionális)

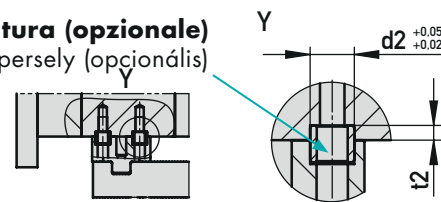
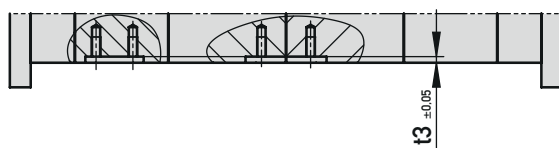

d1	t	t1	d2	t2	t3	r1	h6	l5	h4	l4	h5	l3	l2	h2	h3	l6	F (kN)	L*
M5	12	17	8	3,5	3	5,25	47	18	18	32	36	45	29	79	88	77	8	602,5
																		797
M8	14	20	12	4,5	5	8,5	83	30	28	47,5	67	66	40	136	153	137	12	800
																		1196
M10	18	25	14	4,5	5	8,5	107	30	38	50	82	66	40	171	188	172	22,5	803
																		1192,5
																		1494
																		1796