

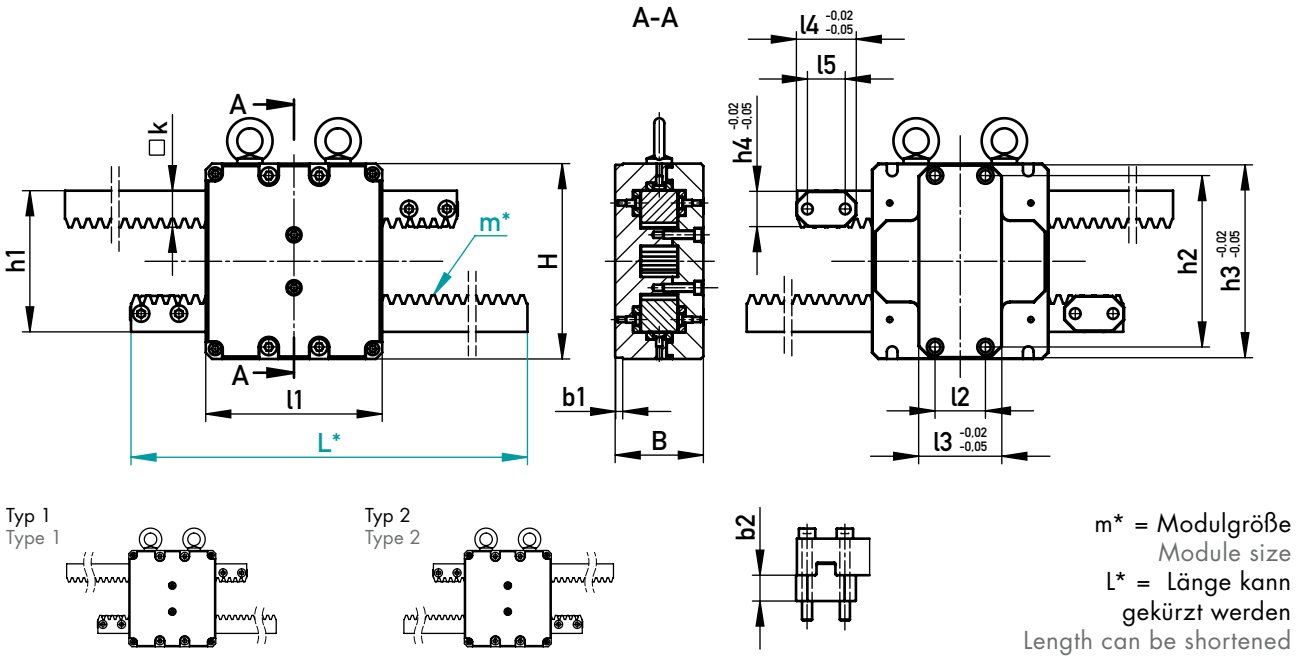

**ZAHNSTANGENGETRIEBE**  
RACK GEAR



**AUF EINEN BLICK**

- › Sehr kompakte Bauweise – mehr als 30% Platzeinsparung zu vergleichbaren Produkten
- › Einfache und schnelle Montage der vormontierten Einheit
- › Kosteneffiziente Systemlösung
- › Ablängen auf Wunschlänge

**AT A GLANCE**

- › Very compact design – saves more than 30% space compared to similar products
- › Pre-assembled units allow easy and quick mounting
- › Cost-efficient system solution
- › Can be cut to required length



Es sind immer zwei oder vier Einheiten am Werkzeug anzubringen.  
Bei Längen (L) >1000 mm zusätzliche Führungen für die Zahnstange prüfen.  
There are always two or four units to be installed on the mould.  
For lengths (L) >1000 mm, check the need for additional guides for the rack.

200 °C

k	b1	l3	h3	b2	h4	l4	h2	l5	l2	h1	l1	B	H	m*	L*	F (kN)	Typ 1 / Type 1	Typ 2 / Type 2
																	☒	☒
19	3,5	45	88	13,5	18	32	79	18	29	66	78	45,5	89	2	602,5	8	461000/1/2-600	461000/2/2-600
																	461000/1/2-800	461000/2/2-800
29	6	66	153	20,5	28	47,5	136	30	40	112	140	70	155	3	800	12	461000/1/3-800	461000/2/3-800
																	461000/1/3-1200	461000/2/3-1200
39	6	66	188	20,5	38	50	171	30	40	146	185	80	190	4	803	22,5	461000/1/4-800	461000/2/4-800
																	461000/1/4-1200	461000/2/4-1200
																	461000/1/4-1500	461000/2/4-1500
																	461000/1/4-1800	461000/2/4-1800



**ZAHNSTANGENGETRIEBE**  
RACK GEAR

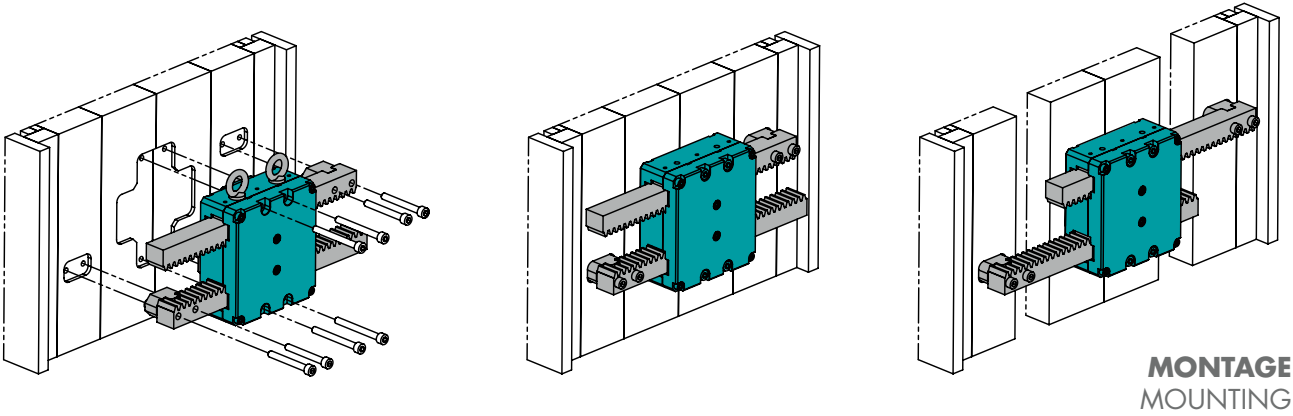

**MONTAGE**  
MOUNTING

**EINBAURAUUM** · MOUNTING SPACE

Beispiel Typ 1  
Example Type 1

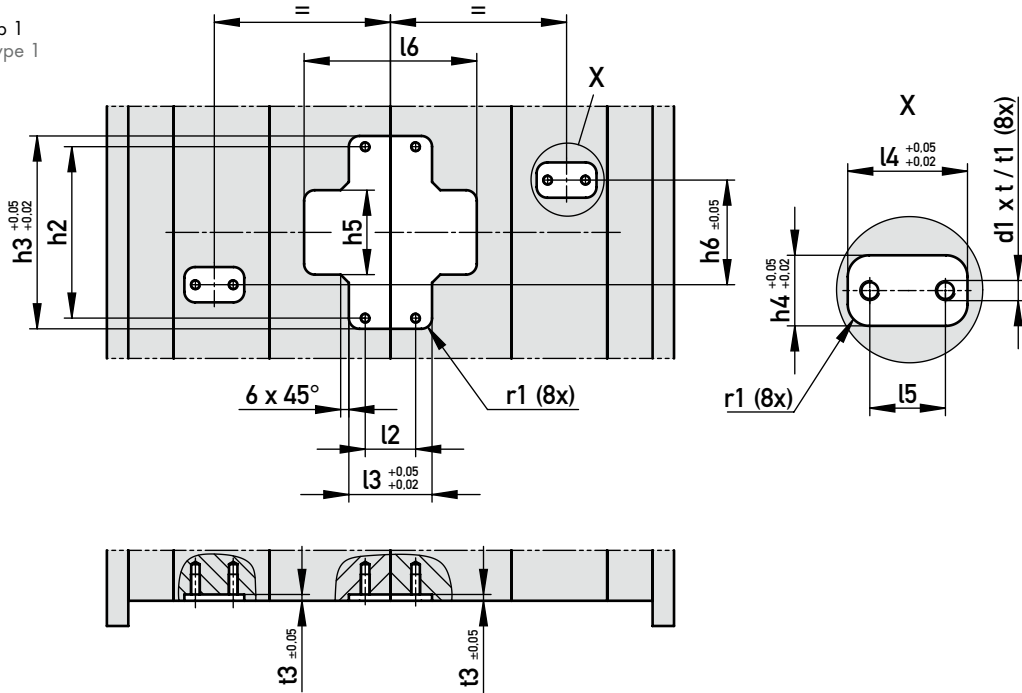

d1	t	t1	d2	t2	t3	r1	h6	l5	h4	l4	h5	l3	l2	h2	h3	l6	F (kN)	L*
M5	12	17	8	3,5	3	5,25	47	18	18	32	36	45	29	79	88	77	8	602,5
																		797
M8	14	20	12	4,5	5	8,5	83	30	28	47,5	67	66	40	136	153	137	12	800
																		1196
M10	18	25	14	4,5	5	8,5	107	30	38	50	82	66	40	171	188	172	22,5	803
																		1192,5
																		1494
																		1796