

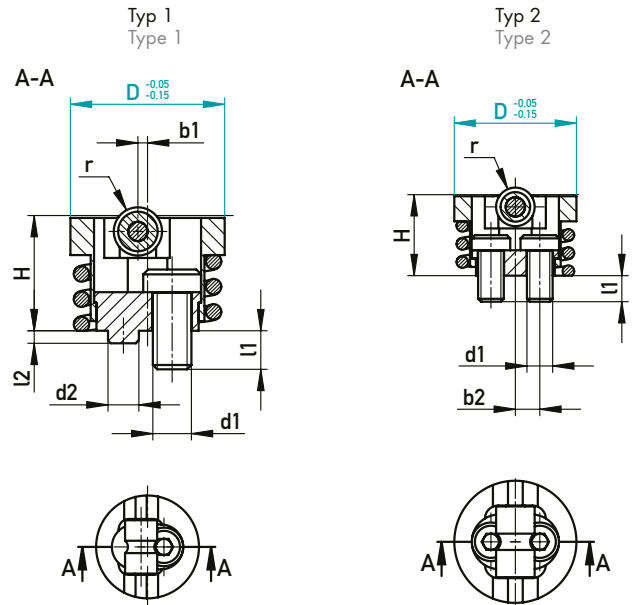

# SCHIEBERHALTEVORRICHTUNG MIT ROLLE

## SLIDE HOLDING DEVICE WITH ROLL



Feder separat erhältlich  
Spring separately available  
295151ET/F-D-m

250°C Gehäuse / Case: 1.7227 / ~30 HRC • Rolle / Roll: 1.3343 / ~60 HRC

Typ/ Type	Farbe/Colour	b1	b2	b3	d1	d2	d3	H	l1	l2	l3	r	D	m (kg)*	€/1
1	● grau/grey	1,2	1	2	M3	2,4	2,5	7,5	3,4	1,1	1,25	1,25	10	1	•
	○ weiß/white													2	•
	● beige/beige													3	•
	● grau/grey	1,4	1,75	2,5	M4	3,2	3,3	9,55	5	1,3	2	2	13	1	•
	○ weiß/white													2	•
2	● orange/orange													4	•
	○ weiß/white	1	2,55	2,5	M4	3,2	3,3	11,95	4	1,3	2	2,5	16	2	•
	● orange/orange													4	•
	● grün/green													9	•
	● orange/orange	-	3,8	-	M4	-	-	12,6	4	-	-	3	19	4	•
	● grün/green	-	-	-	-	-	-	-	-	-	-	-	-	9	•
	● blau/blue	-	-	-	-	-	-	-	-	-	-	-	-	13	•
	● rot/red	-	3,8	-	M4	-	-	19	6,5	-	-	3	22	22	•
	● magenta/magenta	-	-	-	-	-	-	-	-	-	-	-	-	28	•
	● gelb/yellow	-	-	-	-	-	-	-	-	-	-	-	-	36	•
	● rot/red	-	5,2	-	M6	-	-	21,75	7	-	-	4	28	22	•
	● magenta/magenta	-	-	-	-	-	-	-	-	-	-	-	-	28	•
	● gelb/yellow	-	-	-	-	-	-	-	-	-	-	-	-	36	•
● schwarz/black	-	-	-	-	-	-	-	-	-	-	-	-	45	•	
● wasserblau/water blue	-	7,5	-	M6	-	-	42	12	-	-	6	42	80	•	
● lehm Braun/clay brown	-	-	-	-	-	-	-	-	-	-	-	-	120	•	
● verkehrsgrau B/traffic grey B	-	-	-	-	-	-	-	-	-	-	-	-	160	•	

\*Die angegebenen Haltekräfte beziehen sich auf Schieber in ruhender, verrasteter Position.  
The specified retention forces refer to the slider in a resting, locked position.

295151/D-m

### EINBAURAUM • MOUNTING SPACE

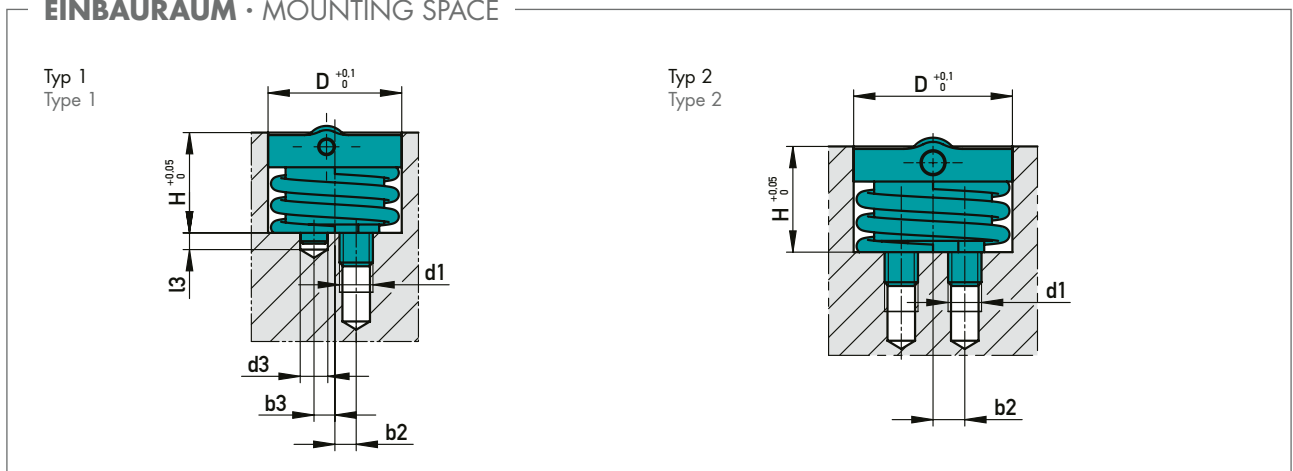

**GROÙE VARIANTENVIELFALT**

- › Austauschbare Federn mit verschiedenen Haltekräften (1 – 160 kg)
- › Verschiedene Abmessungsgrößen (ø 10, 13, 16, 19, 22, 28, 42 mm)

**VARIETY OF VARIANTS**

- › Interchangeable springs with different retention forces (1 – 160 kg)
- › Different dimensions (ø 10, 13, 16, 19, 22, 28, 42 mm)

**EIGENSCHAFTEN**

- › DLC-beschichtete Achse
- › Gehärtete Rolle (60 HRC)
- › Keine Schmierung notwendig
- › Temperaturbeständig bis 250°C
- › Geeignet für Reinraum

**CHARACTERISTICS**

- › DLC coated axis
- › Hardened roll (60 HRC)
- › No lubrication necessary
- › Temperature resistant up to 250°C
- › Cleanroom qualified

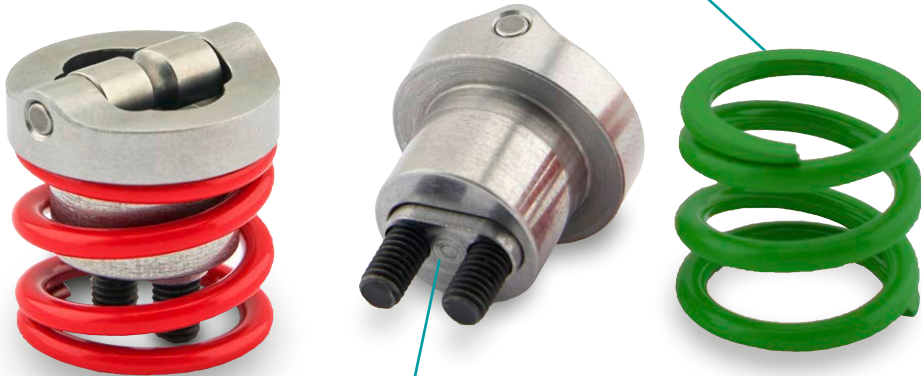

Feder separat erhältlich  
Spring separately available  
› 295151ET/F-D-m

**HOHE PROZESSICHERHEIT**

- › Große Auflagefläche für sicheren Einbau

**HIGH PROCESS SAFETY**

- › Large contact surface for safe installation

**EINFACHE EINARBEITUNG**

- › Keine Nachbearbeitung des Gewindes notwendig (Fase möglich)
- › Schraubengröße: M4 und M6

**EASY MACHINING**

- › No post-machining of the thread necessary (chamfer possible)
- › Screw dimension: M4 and M6

**Einbauraum · MOUNTING SPACE**

Einbau ohne Halteplatte  
Machining without retaining plate

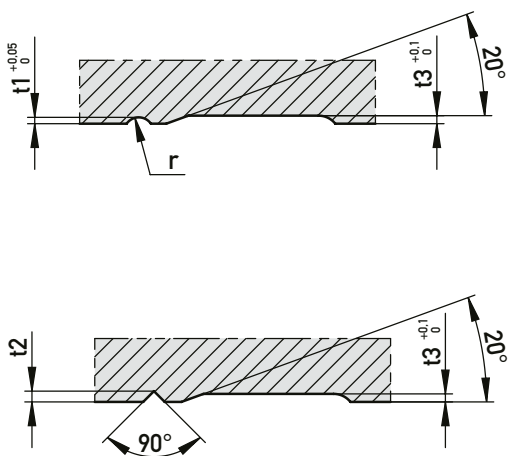

Einbau mit Halteplatte 295152  
Machining with retaining plate 295152

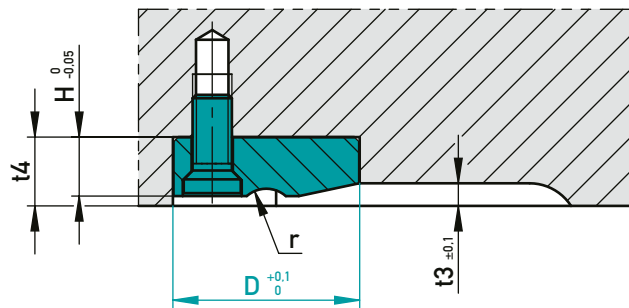

Typ/Type	t1	t2	t3	t4	H	r	D
1	0,4	0,9	0,85	4,5	4,5	1,25	10
	0,85	1,65	1,45	5,85	5,5	2,0	13
		1,85				2,5	16
2	1,1	2,35	1,7	6,35	6,0	3,0	19
	1,25	2,5	2,0	6,5			22
	1,65	3,35	2,65	7,75	7,0	4,0	28
	1,75	4,3	2,75	12,0	12,0	6,0	32



## HALTEPLATTE FÜR 295151

### RETAINING PLATE FOR 295151



Typ 1  
Type 1

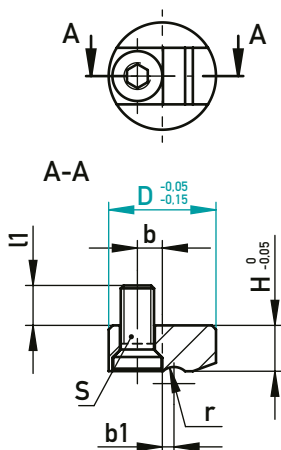

Typ 2  
Type 2

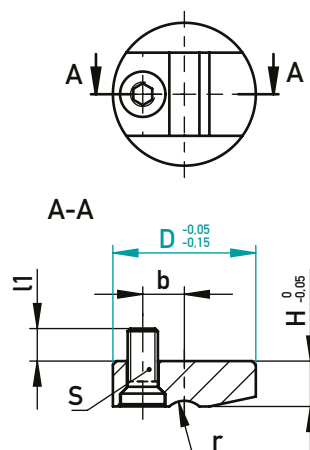

#### AUF EINEN BLICK

- ▶ Einfache, zeitsparende Einarbeitung
- ▶ Erleichtertes Einrasten der Schiebersicherung
- ▶ Empfohlen für nicht gehärtete Platten
- ▶ Minimiert Verschleiß innerhalb der Formplatte
- ▶ Verschleißteil kann einfach getauscht werden

#### AT A GLANCE

- ▶ Simple, time-saving installation
- ▶ Facilitated locking of the slide retainer
- ▶ Recommended for non-hardened plates
- ▶ Minimizes wear on the mould plate
- ▶ Wear part can be replaced easily

✓ Befestigungsschraube im Lieferumfang enthalten / Fastening screw in scope of delivery

⊞ 1.7227/~30 HRC

Typ/Type	f1	f2	f3	f4	l1	S	b	b1	H	r	D	€/1
1	0,4	0,9	0,85	4,5	3,6	M3x8	2,5	1,2	4,5	1,25	10	•
	0,85	1,65	1,45	5,85	4,8	M4x10	3,0	1,4	5,5	2,0	13	•
		1,85						4,0	1,0		2,5	16
2	1,1	2,35	1,7	6,35	4,3		5,5	-	6,0	3,0	19	•
	1,25	2,5	2,0	6,5			6,5	-			22	•
	1,65	3,35	2,65	7,75	5,2	M5x12	8,0	-	7,0	4,0	28	•
	1,75	4,3	2,75	12,0	5,4	M5x16	10,0	-	12,0	6,0	32	•

✉ 295152/D