

SCHIEBERHALTEVORRICHTUNG MIT ROLLE – EINZELTEIL

SLIDE HOLDING DEVICE WITH ROLL – SINGLE PART

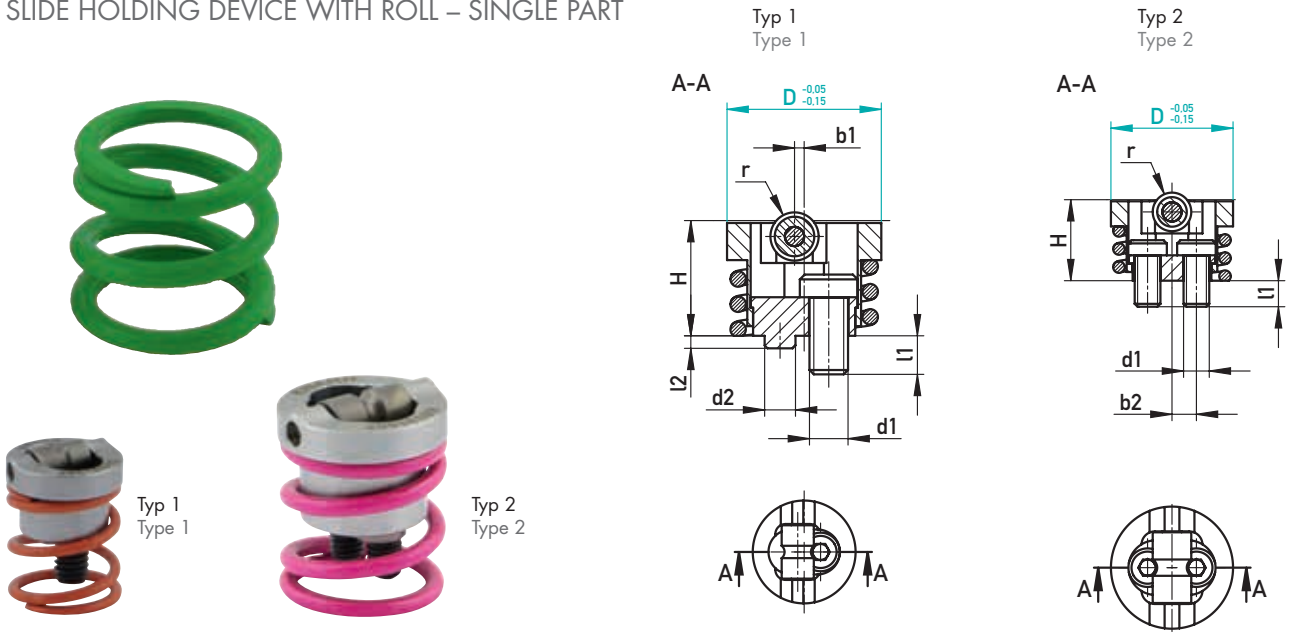

250 °C Gehäuse/Case: 1.7227/~30 HRC • Rolle/Roll: 1.3343/~60 HRC

Typ Type	Farbe Colour	b1	b2	b3	d1	d2	d3	H	l1	l2	l3	r	D	m (kg)*	☒ 295151	☒ 295151ET	€/1
1	● grau/grey	1,2	1	2	M3	2,4	2,5	7,5	3,4	1,1	1,25	1,25	10	1	295151/10-1	295151ET/F-10-1	●
	○ weiß/white													2	295151/10-2	295151ET/F-10-2	●
	● beige/beige													3	295151/10-3	295151ET/F-10-3	●
	● grau/grey	1,4	1,75	2,5	M4	3,2	3,3	9,55	5	1,3	2	2	13	1	295151/13-1	295151ET/F-13-1	●
	○ weiß/white													2	295151/13-2	295151ET/F-13-2	●
	● orange/orange													4	295151/13-4	295151ET/F-13-4	●
	○ weiß/white	1	2,55	2,5	M4	3,2	3,3	11,95	4	1,3	2	2,5	16	2	295151/16-2	295151ET/F-16-2	●
	● orange/orange													4	295151/16-4	295151ET/F-16-4	●
	● grün/green													9	295151/16-9	295151ET/F-16-9	●
2	● orange/orange	-	3,8	-	M4	-	-	12,6	4	-	-	3	19	4	295151/19-4	295151ET/F-19-4	●
	● grün/green													9	295151/19-9	295151ET/F-19-9	●
	● blau/blue													13	295151/19-13	295151ET/F-19-13	●
	● rot/red	-	3,8	-	M4	-	-	19	6,5	-	-	3	22	22	295151/22-22	295151ET/F-22-22	●
	● magenta/magenta													28	295151/22-28	295151ET/F-22-28	●
	● gelb/yellow													36	295151/22-36	295151ET/F-22-36	●
	● rot/red	-	5,2	-	M6	-	-	21,75	7	-	-	4	28	22	295151/28-22	295151ET/F-28-22	●
	● magenta/magenta													28	295151/28-28	295151ET/F-28-28	●
	● gelb/yellow													36	295151/28-36	295151ET/F-28-36	●
	● schwarz/black													45	295151/28-45	295151ET/F-28-45	●
	● wasserblau/water blue	-	7,5	-	M6	-	-	42	12	-	-	6	42	80	295151/42-80	295151ET/F-42-80	●
	● lehmbraun/clay brown													120	295151/42-120	295151ET/F-42-120	●
● verkehrsgrau B/ traffic gray B													160	295151/42-160	295151ET/F-42-160	●	

* Die angegebenen Haltekräfte beziehen sich auf Schieber in ruhender, verrasteter Position. /
The specified retention forces refer to the slider in a resting, locked position.

EINBAURAUM • MOUNTING SPACE

