

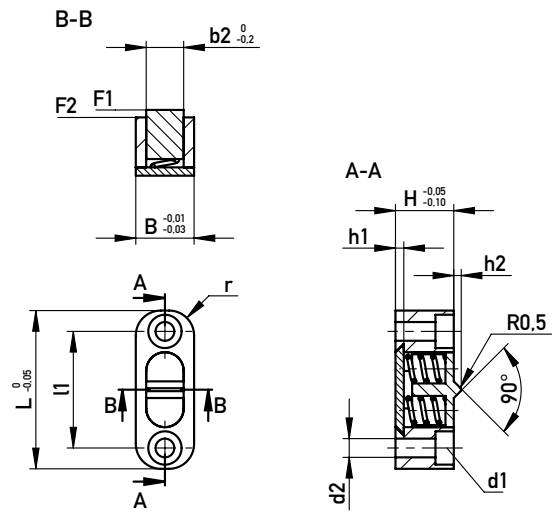

SCHIEBERHALTEVORRICHTUNG
SLIDE HOLDING DEVICE

Typ 0
Type 0



Typ 1
Type 1

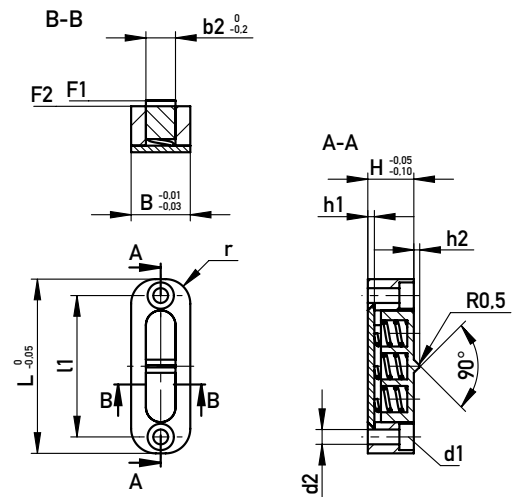

✓ Befestigungsschraube im Lieferumfang enthalten / Fastening screw in scope of delivery

⊗ 1.2343; 1.2312

F1	F2	r	d1	d2	l1	H	h1	h2	b2	L	B	Typ Type	100°C
62 N	70 N	6	M4	M5	28	12	2	1,8	8	38	14	0	295145
114 N	126 N	8	M4	M5	43	14	2	1,8	10	53	18	1	•

☒ 295145/Typ

F1	F2	r	d1	d2	l1	H	h1	h2	b2	L	B	Typ Type	250°C (HT)
52 N	60 N	6	M4	M5	28	12	2	1,8	8	38	14	0	295146
95 N	105 N	8	M4	M5	43	14	2	1,8	10	53	18	1	•

☒ 295146/Typ