

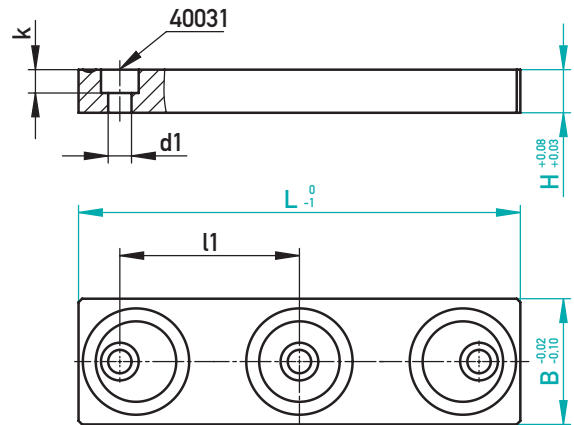

## GLEITLEISTE – GEHÄRTET – DLC

### GLIDING RAIL – HARDENED – DLC



#### AUF EINEN BLICK

- ▶ Optimale Gleit- und Trockenlaufeigenschaften durch DLC-Beschichtung
- ▶ Zusätzliche Schmiernuten
- ▶ System-Bohrabstand 50 mm (l1)
- ▶ Individuelles Kürzen auf Wunschlänge möglich

#### AT A GLANCE

- ▶ Optimal gliding and dry run properties achieved by DLC coating
- ▶ Additional oil grooves
- ▶ System bore pitch 50 mm (l1)
- ▶ Individual cutting to desired length possible

1.2842 + DLC / ~58 HRC

40031	d1	k	l1	B	H	L	€/1
M6-16	6,5	6,5	50	35	12	123	•
						173	•
						223	•
						373	•
M6-16	6,5	6,5	50	50	12	123	•
						173	•
						223	•
						373	•

✉ 285040/B-H-L

