

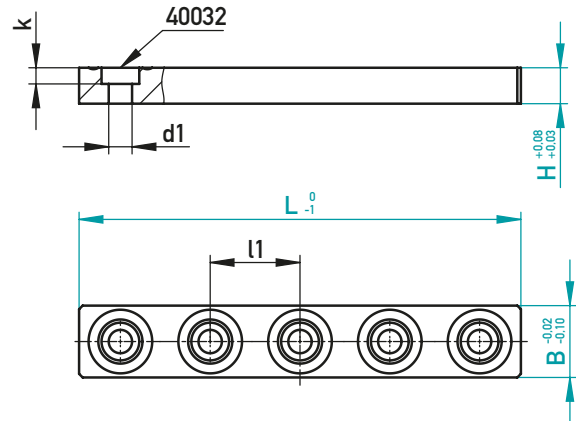

**GLEITLEISTE – GEHÄRTET – DLC**  
GLIDING RAIL – HARDENED – DLC

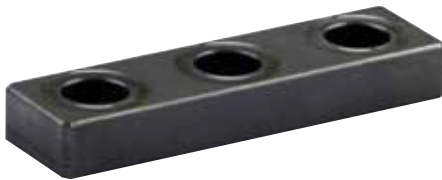

**AUF EINEN BLICK**

- ▶ Optimale Gleit- und Trockenlaufeigenschaften durch DLC-Beschichtung
- ▶ Zusätzliche Schmiernuten
- ▶ System-Bohrabstand 25 mm (l1)
- ▶ Individuelles Kürzen auf Wunschlänge möglich

**AT A GLANCE**

- ▶ Optimal gliding and dry run properties achieved by DLC coating
- ▶ Additional oil grooves
- ▶ System bore pitch 25 mm (l1)
- ▶ Individual cutting to desired length possible

1.2842 + DLC / ~58 HRC

40032	d1	k	l1	B	H	L	€/1
M5-10	5,5	3,8	25	12	6	48	•
						73	•
						98	•
						148	•
M5-12	5,5	4	25	15	8	48	•
						73	•
						98	•
						123	•
M5-10	5,5	3,8	25	20	6	48	•
						73	•
						98	•
						123	•
M5-10	5,5	3,8	25	20	6	148	•
						198	•
						198	•
						198	•
M6-16	6,5	4,5	25	20	10	48	•
						73	•
						98	•
						123	•
M6-16	6,5	4,5	25	20	10	148	•
						148	•
						148	•
						298	•

40032	d1	k	l1	B	H	L	€/1
M5-12	5,5	4	25	25	8	48	•
						73	•
						98	•
						123	•
M5-12	5,5	4	25	25	8	148	•
						198	•
						198	•
						198	•
M6-16	6,5	4,5	25	30	10	48	•
						73	•
						98	•
						123	•
M6-16	6,5	4,5	25	40	10	73	•
						98	•
						123	•
						148	•
M6-16	6,5	4,5	25	40	10	198	•
						198	•
						198	•
						298	•

282540/B-H-L

