

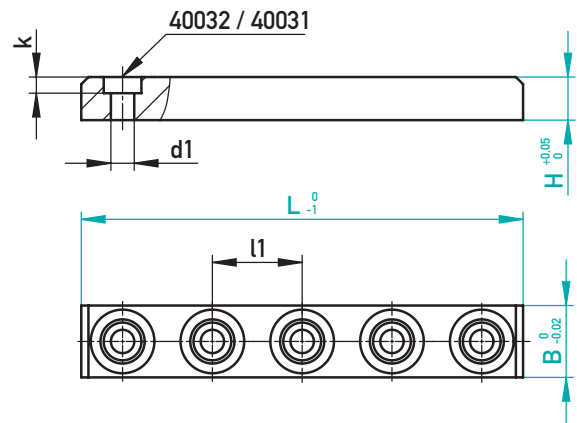

## FÜHRUNGSLEISTE, MITTIG - GEHÄRTET - DLC

GUIDE RAIL, CENTRED - HARDENED - DLC



### AUF EINEN BLICK

- ▶ Ideal für komplexe oder große Schieberkonstruktionen
- ▶ Führung bei temperaturbedingter Ausdehnung
- ▶ Optimale Gleit- und Trockenlaufeigenschaften durch DLC-Beschichtung
- ▶ Zusätzliche Schmiernuten
- ▶ System-Bohrabstand 25 mm (l1)
- ▶ Individuelles Kürzen auf Wunschlänge möglich

### AT A GLANCE

- ▶ Ideal for complex or large slide designs
- ▶ Guiding in the event of temperature-related expansion
- ▶ Optimal gliding and dry run properties achieved by DLC coating
- ▶ Additional oil grooves
- ▶ System bore pitch 25 mm (l1)
- ▶ Individual cutting to desired length possible

1.2379 + DLC / ~59 HRC

40031 / 40032	d1	k	l1	B	H	L	€/1
40032/M4-10	4,5	3,3	25	10	6	48	•
						73	•
						98	•
						248	•
40032/M6-12	6,5	4,5	25	15	10	48	•
						73	•
						98	•
						123	•
40032/M6-16	6,5	4,5	25	20	12	298	•
						73	•
						98	•
						123	•
40031/M6-20	6,5	7	25	20	20	73	•
						98	•
						123	•
						148	•
40031/M6-20	6,5	7	25	30	20	298	•
						98	•
						123	•
						148	•
						198	•
						298	•

☒ 282520/B-H-L

